

ID NUMBER	
PREPARATION	17-02-14

LDS1.5 SPECIFICATIONS

MODEL : HLS-LFCD2



1. Basic Performance Specification

Items	Specifications
Operating supply voltage*	5VDC±5%
Light source	Semiconductor Laser Diode($\lambda=785\text{nm}$)
Laser safety	IEC60825-1 Class 1
Current consumption	400mA or less (Rush current 1A)
Detection distance	120mm ~ 3,500mm
Interface	3.3V USART (230,400 bps) 42bytes per 6 degrees, Full Duplex option.
Ambient Light Resistance	10,000 lux or less
Sampling Rate	1.8kHz
Dimensions	69.5(W) X 95.5(D) X 39.5(H)mm
Mass	Under 125g

* Target : white paper (Lambertian reflectance $\geq 80\%$)

2. Standard Performance

Measurement performance		
Items	Spec.	Remarks
(1) Distance		White objects - Lambertian Reflectance ≥80%
Distance Range	120 ~ 3,500mm	
Distance Accuracy *	±15mm ±5.0%	
Distance Precision **	(±)10mm (±) 3.5%	
(2) Rotation		
Scan Rate	300±10 rpm	
Angular Range	360°	
Angular Resolution	1°	

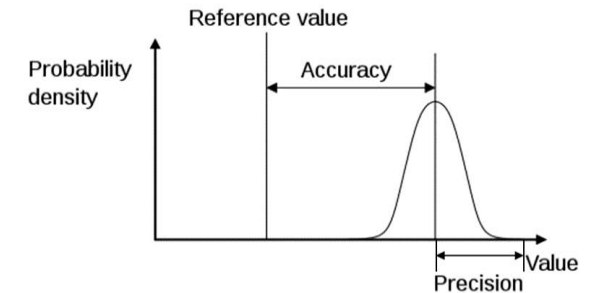

* Accuracy = Distance Average - Reference Value

** Precision = $\frac{Max. - Min.}{2}$

3. Mechanism Layout

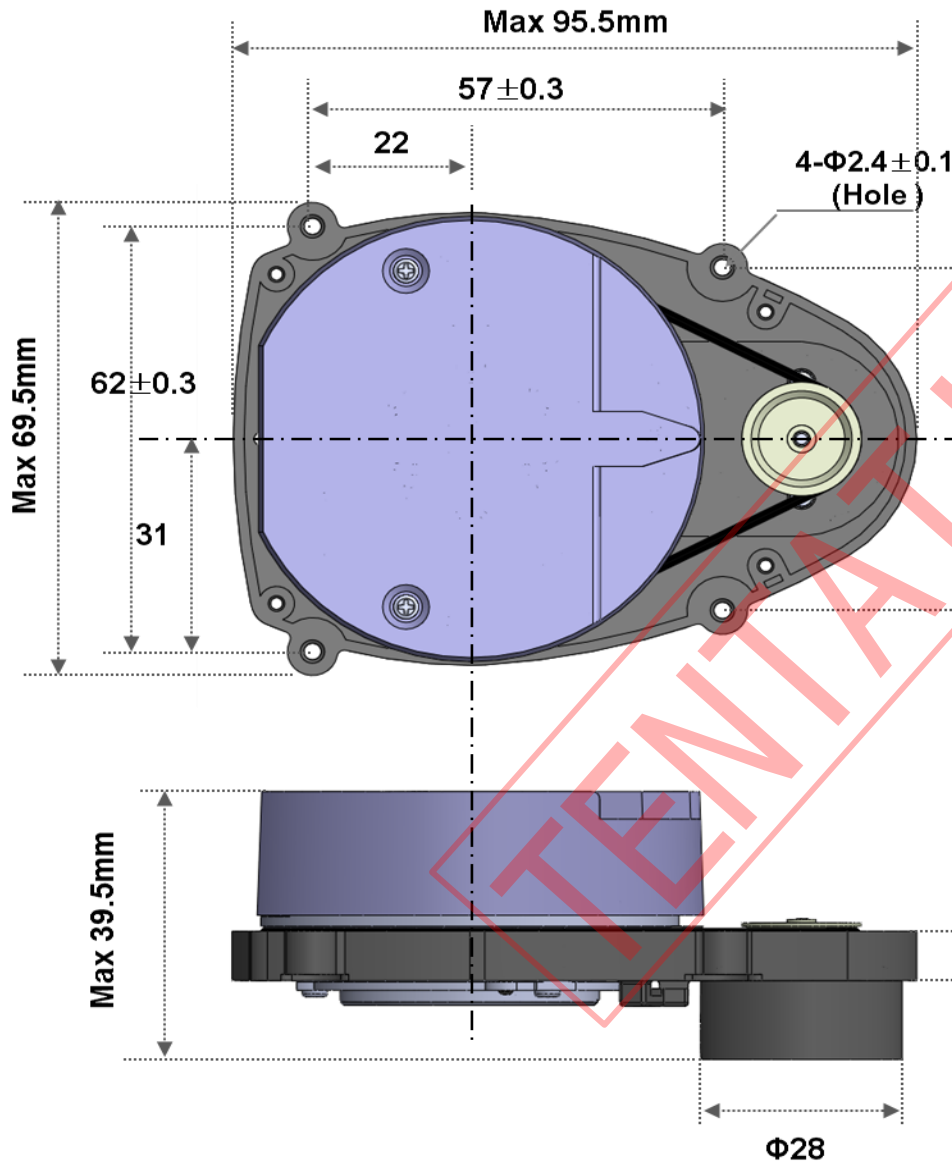

GRADE	DIMENSIONAL TOLERANCE						
	4	5	13	37	111	331	1000
①	±0.10	±0.15	±0.20	±0.30	±0.45	±0.70	±1.0
2	±0.15	±0.20	±0.30	±0.45	±0.70	±1.0	±1.5
3	±0.20	±0.30	±0.45	±0.70	±1.0	±1.5	±2.0
4	±0.30	±0.45	±0.70	±1.0	±1.5	±2.0	±3.0
5	±0.45	±0.70	±1.0	±1.5	±2.0	±3.0	±4.0

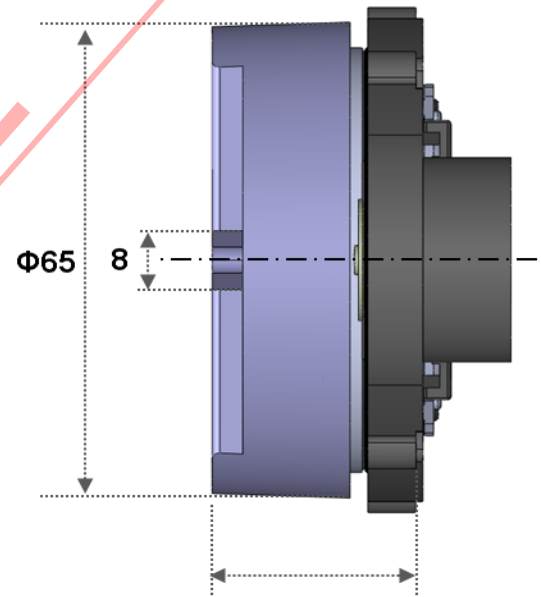

MAX : 27.1mm
 Typical : 26.9mm

Bottom line of boss
 for robot cleaner(Origin line)

4. Optical Path (9.4mm)

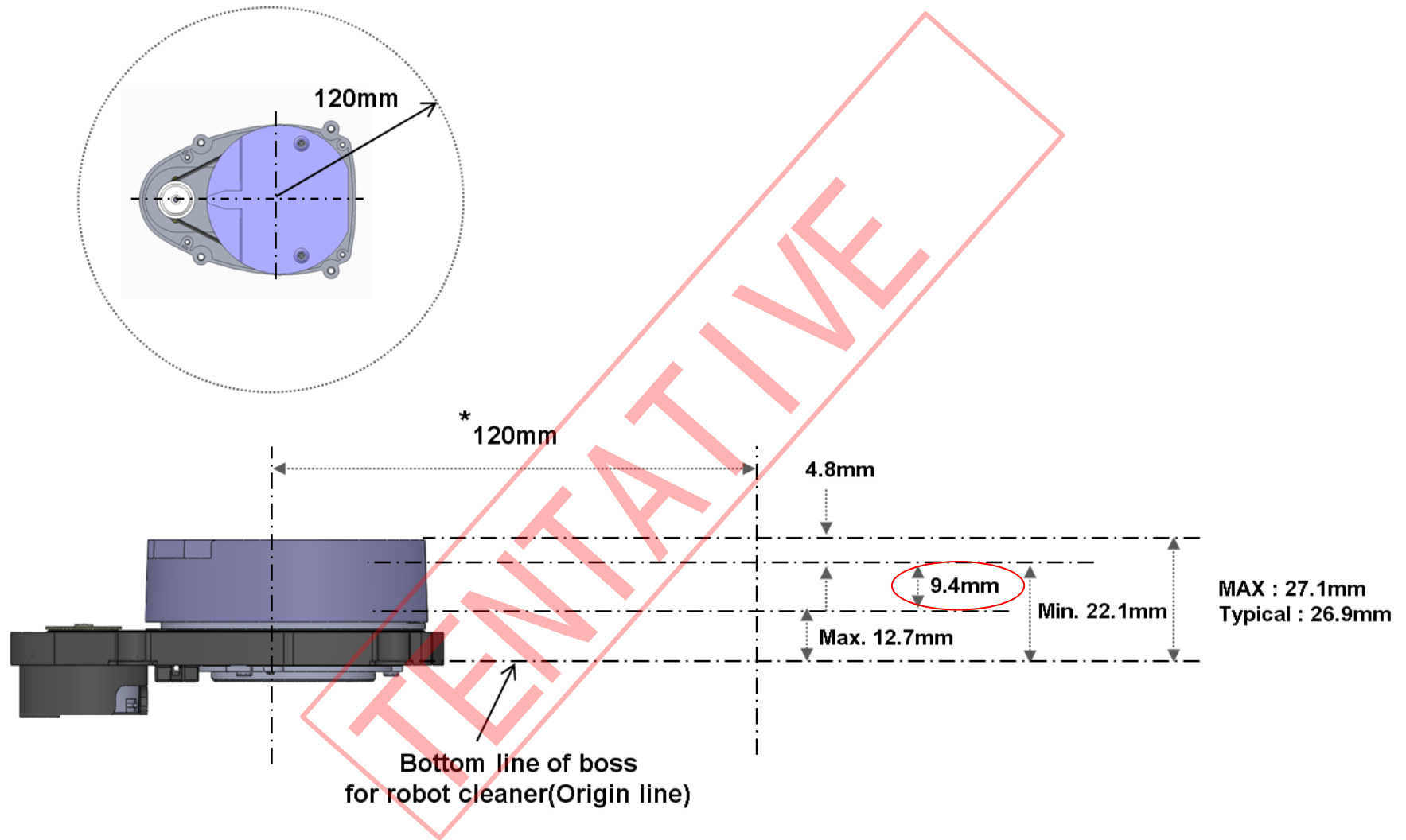

* If the position is different, please contact HLDS about the exact dimension.

5. DATA INFORMATION

0	sync	FA	Fix	
1	degree	A1	Angle Index	0xA0~0xDB (0~60)
2	RPM	C3	RPM	low
3		0B		high
4	Intensity	B0	Angle offset 0	low
5		22		high
6	Dist_M	8B		low
7		00		high
8	Reserved*	00		low
9		00		high
10	Intensity	2C	Angle offset 1	low
11		30		high
12	Dist_M	89		low
13		00		high
14	Reserved*	00	low	
15		00	high	
16	Intensity	42	Angle offset 2	low
17		27		high
18	Dist_M	8A		low
19		00		high
20	Reserved*	00		low
21		00		high
22	Intensity	3C	Angle offset 3	low
23		21		high
24	Dist_M	8C		low
25		00		high
26	Reserved*	00	low	
27		00	high	
28	Intensity	C6	Angle offset 4	low
29		0E		high
30	Dist_M	98		low
31		00		high
32	Reserved*	00	low	
33		00	high	
34	Intensity	3F	Angle offset 5	low
35		16		high
36	Dist_M	A4		low
37		00		high
38	Reserved*	00		low
39		00		high
40	Checksum	13	low	
41		13	high	

1) angle = angle index*6 + angle offset

2) checksum information:

add all data 40bytes → checksum = 0xFF – checksum → save to 40, 41bytes
(if calculated checksum is same with 40byte or 41byte, all data is valid.)

* This is reserved for compatibility

6. Pin Description & Command

• LDS 6-pin

No.	Pin Name	Signal Description
6	Vcc(+5.0V)	Power supply for LDS core
5	TX	Serial output for host
4	PWM	LDS motor control PWM signal
3	GND	Ground
2	RX	Input signal for LDS operation
1	BOOT0	Boot mode pin for update F/W (Used only HLDS)

• Motor 2-pin

No.	Pin Name	Signal Description
2	Vcc(+5.0V)	Power supply for LDS Spindle motor
1	PWM	LDS motor control PWM signal

* Host circuit needs internal connections as above

• Command

Key	Description
b	Begin operation (motor state & sensor)
e	Pause operation

7-1 RECOMMENDED CONNECTOR(LDS – 6Pin)

Pin	Model No.	Dimensions(mm)		
	TOP entry type	A	B	C
6	11257W00-NP-S	6.25	10.75	6.70

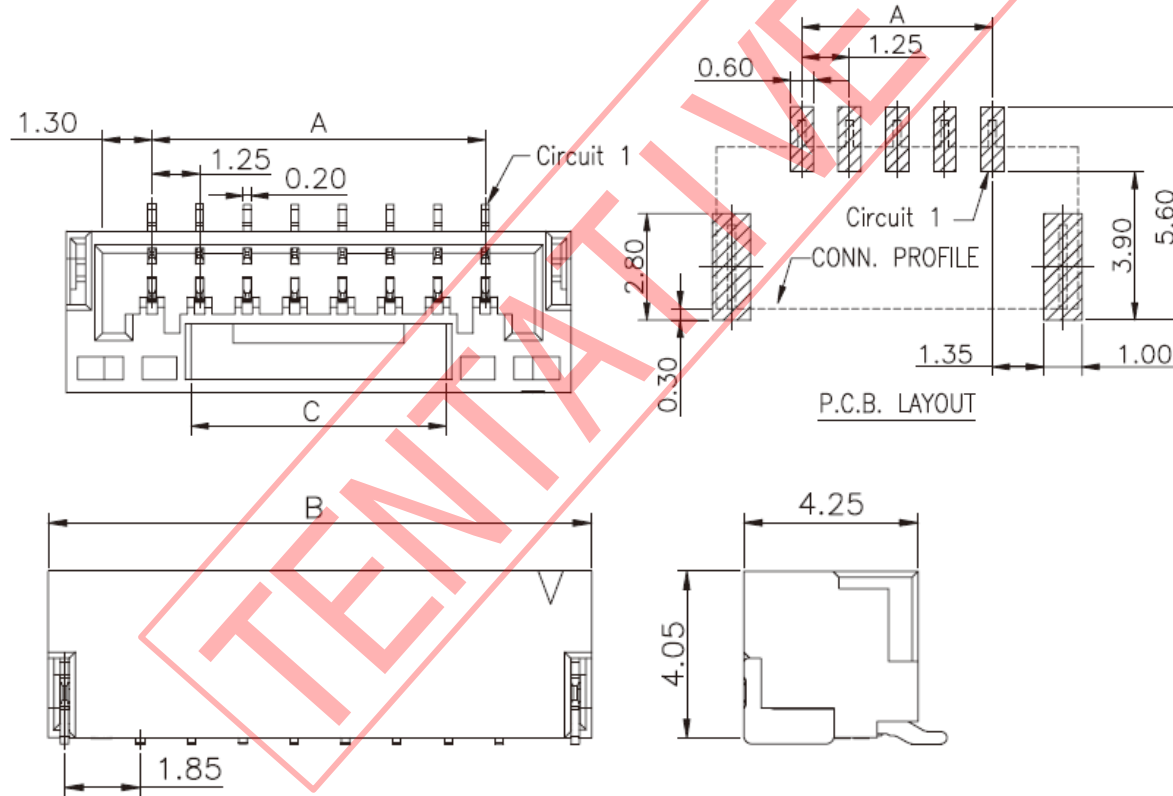

7-2 RECOMMENDED CONNECTOR(Motor – 2Pin)

Pin	Model No.	Dimensions(mm)			
	TOP entry type	A	B	C	D
2	SMW200-H02G	8.0	4.7	2.0	2.9

